



MA109M Smart Single Phase Meter

MA109M is the Single phase AMI meter. Due to the Integrated design and innovative industrial solution, It is only 50% as volume as traditional products, which may significantly lower the cost of customer transportation and storage

The MA109M supports Prime 1.36 and Prime 1.4 in one hard design.



Long lifecycle with high quality control



Safe electricity protection:
Z-Load and Breaker Voltage detection



Neutral Current



Prime 1.3.6 and 1.4

MA109M Smart Single Phase Meter Datasheet



Main features

Energy Register

- ✓ Instantaneous values: Import/export/absolute active and reactive energy
Voltage/current/power/PF/Vrms/Irms/Frequency/Angle
- ✓ Neutral Current
- ✓ Energy load profile: incremental/Absolute values
- ✓ Quality profiles
- ✓ Billing: end of billing/current billing/Daily billing
- ✓ Average RMS values

Power Quality Monitoring

- ✓ Sag & Swell
- ✓ Long Interruptions

TOU

- ✓ Support 3 contracts, contract power(1 and 3)
- ✓ Programmable tariff structure: up to 24 periods per day, up to 12 weekly program, up to 12 seasons, 30 definable special days;
- ✓ Max demand in the import direction and export direction

Real Time Clock

- ✓ Clock accuracy according to EN 62054-21; clock is synchronized internally by internal quartz battery as the backup energy

Communication Interface

- ✓ Communication interface1: Optical interface, IEC 62056-21
- ✓ Communication interface2: PLC Prime interface, compatible with both v1.3 and v1.4
- ✓ Communication interface3: RS485

Events&Alarms

- ✓ Support different Event type: Standard/Service switch/Power quality/Neutral loss/Fraud/Demand management/High frequency/Security event
- ✓ Support alarm and event push

Load Control

- ✓ Internal switch according to UC2 specified in IEC 62052-31
- ✓ Load control according to power threshold
- ✓ High impedance detection
- ✓ Load voltage detection(under relay disconnect)
- ✓ Protection against temporary over voltages

LEDs

- ✓ the meter has two LEDs
- ✓ one LED for consumption(active or reactive can be configured)
- ✓ one LED for Prime communication, three colors, to indicate the different status

Overall dimensions

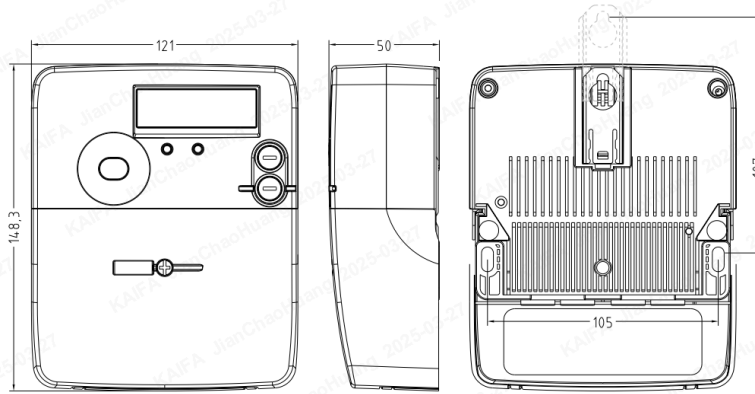

During the transportation, the hook is slide into housing to increase the container capacity
 During the installation, the hook need be slide out

Meter cover sealing method

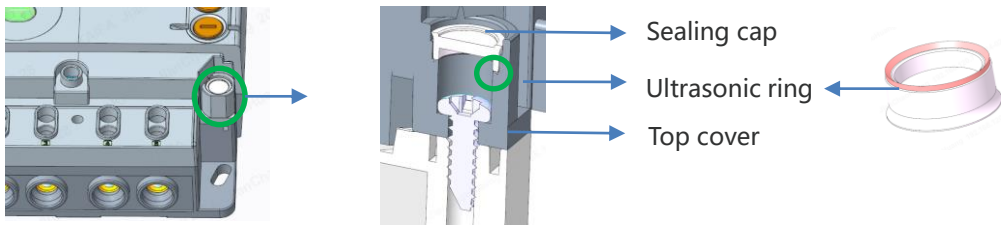

Note: the RS 485 is in the left side

Installation related information

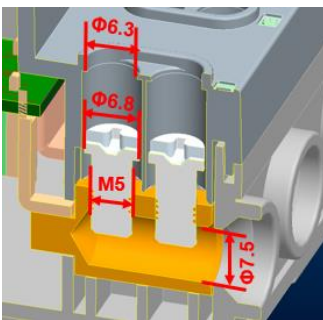

www.kaifametering.com

.No. 99 Tianquan Rd., Hi-Tech Development Zone, Chengdu, P.R.C

Tel: +86-28-65706888

Fax: +86-28-65706889

E-mail: metering@kaifa.cn

 @ Kaifa Metering

 @ Kaifa Metering

 @ Kaifa Metering

 @ Shenzhen Kaifa Technology (Chengdu) Co., Ltd.